

SC530 53 BD GO / SC530 53 B GO

INSTRUCTION FOR USE

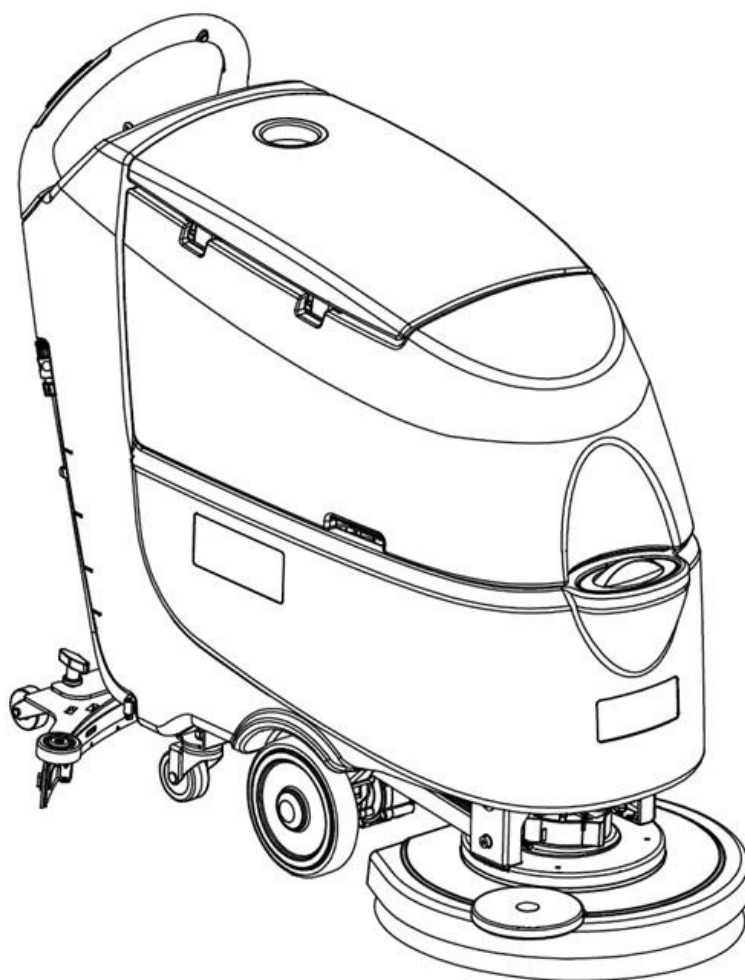

Model: 50000335 / 50000336

VS13009 Rev A 18 Apr. 2016



 **Nilfisk**

Сертификат за съответствие
Osvědčení o shodě
Konformitätserklärung
Överensstämlescifikat
Declaración de conformidad
Vastavussertifikaat Déclaration de
conformité Yhdenmukaisuustodistus

Conformity certificate
Πιστοποιητικό συμμόρφωσης
Megfelelősségi nyilatkozat
Dichiarazione di conformità
Atitikties deklaracija Atbilstības
deklarācija
Konformitetssertifisering
Conformiteitsverklaring

Declaração de conformidade
Declaracja zgodności Certificat
de conformitate Заявление о
соответствии
Överensstämlescifikat
Certifikát súladu
Certifikat o ustreznosti Uyumluluk
sertifikası



Модел / Model / Modell / Model / Modelo / Mudel / Modèle / Malli /
Model / Μοντέλο / Modell / Modello / Modelis / Modelis / Modell / Model
/ Modelo / Model / Model / Модель / Modell / Model / Model / Model :

SC530 53 BD GO/SC530 53 B GO

Тип / Typ / Typ / Type / Tipo / Tyypp / Type / Tuurpi / Type / Τύπος / Típus
/ Tipo / Típas / Tips / Type / Type / Tipo / Typ / Tip / Тип / Typ / Typ / Tip
/ Tip

Scrubber Dryer

Сериен номер / Výrobní číslo / Seriennummer / Seriennummer / Número de serie / Seerianumber / Numéro de série / Sarjanumero / Serial
number / Σειριακός αριθμός / Sorozatszám / Numero di serie / Serijos numeris / Sērijas numurs / Seriennummer / Seriennummer / Número de
série / Numer serijny / Număr de serie / Серийный номер / Seriennummer / Výrobné číslo / Serijska številka / Seri Numarası :

Година на производство / Rok výroby / Baujahr / Fabrikationsår / Año de fabricación / Väljallaskeasta / Année de fabrication / Valmistusvuosi
/ Year of construction / Έτος κατασκευής / Gyártási év / Anno di costruzione / Pagaminimo metai / Izgatavošanas gads / Byggeår / Baujaar /
Año de fabric / Rok produkcji / Anul fabricației / Год выпуска / Tillverkningsår / Rok výroby / Leto izdelave / Leto izdelave / İmal yılı :

BG Долуподписаният потвърждава, че гореспоменатият модел е произведен в съответствие със следните директиви и стандарти. Техническият файл е съставен от производителя.

GB The undersigned certify that the above mentioned model is produced in accordance with the following directives and standards. The technical file is compiled by the manufacturer.

P A presente assinatura serve para declarar que os modelos supramencionados são produtos em conformidade com as seguintes directivas e normas. A ficha técnica é redigida pelo fabricante.

CZ Niže podepsaný stvrzuje, že výše uvedený model byl vyroben v souladu s následujícími směrnici a normami. Autorem technického listu je výrobce.

GR Ο κάτωθι υπογεγραμμένος πιστοποιεί ότι η παραγωγή του προαναφερθέντος μοντέλου γίνεται σύμφωνα με τις ακόλουθες οδηγίες και πρότυπα. Το τεχνικό αρχείο συντάσσεται από τον κατασκευαστή.

PL Niżej podpisany zaświadcza, że wymieniony powyżej model produkowany jest zgodnie z następującymi dyrektywami i normami. Dokumenty techniczne zostały przygotowane przez producenta

D Der Unterzeichner bestätigt hiermit dass die oben erwähnten Modelle gemäß den folgenden Richtlinien und Normen hergestellt wurden. Die technische Dokumentation wird vom Hersteller erstellt.

H Alulirottak igazoljuk, hogy a fent említett modellt a következő irányelvek és szabványok alapján hoztuk létre. A műszaki fájlt a gyártó készítette.

RO Subsemnatul atest că modelul susmenționat este produs în conformitate cu următoarele directive și standarde. Fișierul tehnic este redactat de către producător.

DK Undertegnede attesterer herved, at ovennævnte model er produceret i overensstemmelse med følgende direktiver og standarder. Den tekniske fil er udarbejdet af fabrikanten.

I Il sottoscritto dichiara che i modelli sopra menzionati sono prodotti in accordo con le seguenti direttive e standard. Il fascicolo tecnico è redatto dal costruttore.

RUS Настоящим удостоверяется, что машина вышеуказанной модели изготовлена в соответствии со следующими директивами и стандартами. Техническая документация составлена производителем.

E El abajo firmante certifica que los modelos arriba mencionados han sido producidos de acuerdo con las siguientes directivas y estándares. El fascículo técnico está redactado por el fabricante

LT Toliau pateiktu dokumentu patvirtinama, kad minėtas modelis yra pagamintas laikantis nurodytų direktyvų bei standartų. Techninę bylą sudarė gamintojas.

S Undertecknad intygar att ovannämnda modell är producerad i överensstämmelse med följande direktiv och standarder. Den tekniska filen är sammanställd av tillverkaren.

EST Allakirjutanu kinnitab, et ülalnimetatud mudel on valmistatud kooskõlas järgmiste direktiivide ja normidega. Tehnilise dokumentatsiooni koostab tootja.

LV Ar šo tiek apliecināts, ka augstākminētais modelis ir izgatavots atbilstoši šādām direktīvām un standartiem. Tehnisko aprakstu ir sastādījis ražotājs.

SK Dolu podpísaný osvedčuje, že hore uvedený model sa vyrába v súlade s nasledujúcimi smernicami a normami. Technický súbor vytvoril výrobca.

F Je soussigné certifie que les modèles ci-dessus sont fabriqués conformément aux directives et normes suivantes. Le dossier technique est rédigé par le fabricant.

N Undertegnede attesterer att ovennævnte modell är produceret i överensstemmelse med följande direktiv och standarder. Den tekniske filen er opprettet av produsenten

SLO Spodaj podpisani potrjujem, da je zgoraj omenjeni model izdelan v skladu z naslednjimi smernicami in standardi. Spis s tehnično dokumentacijo pripravi izdelovalec.

FIN Allekirjoittain vakuuttaa että yllämainittu malli on tuotettu seuraavien direktiivien ja standardien mukaan. Valmistaja kääntää teknisen tiedoston.

NL Ondergetekende verzekert dat de bovengenoemde modellen geproduceerd zijn in overeenstemming met de volgende richtlijnen en standaards. Het technische bestand is door de fabrikant samengesteld.

TR Aşağıda İmzası olan kişi, yukarıda bahsedilen model cihazın aşağıda verilen direktiflere ve standartlara uygunlukta imal edildiğini onaylar. Teknik dosya üretici tarafından derlenmiştir.

EC Machinery Directive 2006/42/EC

EN ISO 12100, EN ISO 13857, EN 349, EN 982

EN 60335-1, EN 60335-2-69, EN 60335-2-72

EC EMC Directive 2004/108/EC

EN 55014-1, EN 55014-2, EN 61000-3-2, EN 61000-3-3

Производителя / Výrobce / Hersteller / Fabrikanten / Fabricante / Tootja / Fabricant / Valmistaja / Manufacturer Κατασκευαστή / Gyártó /
Costruttore / Gamintojas / Ražotājs / Produzenten / Fabrikant / Fabricante / Producenta Producător / Производителем / Tillverkaren /
Výrobca / Izdelovalec / Üretici :

Nilfisk A/S Kornmarksvej 1 DK-2605 Brøndby Denmark

Tel: + 45 43 23 81 00

Fax: + 45 43 43 77 00

Authorized signatory: Alex Sin, Vice President

Date: 29 Apr.2016

Signature:

TABLE OF CONTENTS

INTRODUCTION	2
MANUAL CONTENT AND PURPOSE.....	2
HOW TO KEEP THIS MANUAL.....	2
DECLARATION OF CONFORMITY.....	2
ACCESSORIES AND MAINTENANCE.....	2
CHANGE AND IMPROVEMENT.....	2
SCOPE OF APPLICATION.....	2
MACHINE IDENTIFICATION DATA.....	2
TRANSPORT AND UNPACKING.....	3
 SAFETY	 3
VISIBLE SYMBOLS ON THE MACHINE.....	3
SYMBOLS THAT APPEAR ON THE INSTRUCTION FOR USE MANUAL.....	3
GENERAL SAFETY INSTRUCTION.....	4
 MACHINE DESCRIPTION	 6
MACHINE STRUCTURE.....	6
CONTROL PANEL.....	7
DISPLAY WINDOW OF CHARGER INDICATON LIGHT.....	7
TECHNICAL PARAMETERS.....	8
WIRING DIAGRAM.....	9
 OPERATING GUIDE	 11
BATTERY CHECK/SETTING ON A NEW MACHINE.....	11
BATTERY INSTALLATION AND BATTERY TYPE SETTING (WET OR GEL/ AGM).....	12
BRUSH/PAD-HOLDER INSTALLATION AND UNINSTALLATION.....	13
ADJUSTING THE BALANCE OF SQUEEGEE.....	13
SOLUTION OR WASHING WATER TANK FILLING.....	14
DETERGENT TANK FILLING (FOR MACHINES WITH CHEMICAL MIXING SYSTEM).....	14
MACHINE START AND STOP.....	15
MACHINE OPERATION (SCRUBBERING AND DRYING).....	16
TANK EMPTYING.....	17
AFTER USING THE MACHINE.....	18
MACHINE LONG INACTIVITY.....	18
FIRST PERIOD OF USE.....	18
 MAINTENANCE	 19
SCHEDULED MAINTENANCE TABLE.....	19
BATTERY CHARGING.....	20
BRUSH/PAD CLEANING.....	21
SOLUTION FILTER CLEANING.....	21
SQUEEGEE CLEANING.....	22
SQUEEGEE BLADE CHECK AND REPLACEMENT.....	23
TANK AND VACUUM GRID WITH FLOAT CLEANING, AND COVER GASKET CHECK.....	24
DETERGENT TANK CLEANING.....	25
MACHINE WORKING HOUR CHECK.....	25
FUSE CHECK/REPLACEMENT.....	26
ACCESSORIES/OPTIONS.....	27
 TROUBLESHOOTING	 27
 SCRAPPING	 27

INTRODUCTION



NOTE

The numbers in brackets refer to the components shown in Machine Description chapter.

MANUAL CONTENT AND PURPOSE

The purpose of this Instruction for Use Manual is to provide the operator with necessary information to use the machine properly and safely. It contains information about technical data, safety, operation, storage, maintenance, spare parts and how to scrap it.

Before performing any procedure on the machine, no matter the operators and qualified technicians must read this Manual carefully. Contact our company service center for any query about this manual or for any further information is needed.

The operators must not perform procedures that should be done by qualified technicians. Our company will not be answerable for damages coming from the non-observance of this prohibition.

HOW TO KEEP THIS MANUAL

The Manual must be kept near the machine, inside an adequate case, away from liquids and other substances that can cause any damage to it.

DECLARATION OF CONFORMITY

Declaration of Conformity is supplied with the machine and certifies machine conformity with the law in force.



NOTE

The copies of the original declaration of conformity are provided together with the machine documentation.

ACCESSORIES AND MAINTENANCE

All the necessary operation, maintenance and repair procedures must be performed by qualified personnel, or by our company appointed service center. ONLY authorized spare parts and accessories should be used.

Contact our company customer service for any service or purchase of accessories or spare parts if necessary.

CHANGE AND IMPROVEMENT

We committed to continuous improvement of its products, the company reserves the right to the machine changes and improvements without informing in additional.

SCOPE OF APPLICATION

The scrubber applies to commercial and industrial use. It is suitable for cleaning smooth and solid floor, operating by a qualified personnel in safety circumstance. It is not suitable for outdoor use or carpet or rough floor cleaning.

MACHINE IDENTIFICATION DATA

The machine serial number and model name are marked on the serial label.

This information is useful. Use the following table to write down the machine identification data when requiring spare parts for the machine.

MACHINE MODEL.....
MACHINE SERIAL NUMBER.....

TRANSPORT AND UNPACKING

When the carrier delivers the machine, make sure the packaging and machine are both whole and undamaged. If any damaged, make the carrier know the damage and before accepting the goods, reserve the right in compensation of the damage.

Follow the instructions on packing strictly when unpacking the machine.

Check the package to ensure following items are included:

1. Technical documentations including Quick Start Guide manual, Instruction for Use Disk and on-board charger manual if on-board charger is equipped.
2. Charger cable if on-board charger is equipped.
3. Two fuses, the low power circuit fuse (5A) and the Brush release fuse (20A).

SAFETY

The following symbols indicate potentially dangerous situations. Always read this information carefully and take all necessary precautions to safeguard people and property.

VISIBLE SYMBOLS ON THE MACHINE

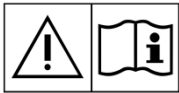

WARNING!

Read all the instructions carefully before performing any operation on the machine.



WARNING!

Do not wash the machine with direct or pressurized water jets.



WARNING!

Do not use the machine on slopes with a gradient exceeding that is defined in the specification.

SYMBOLS THAT APPEAR ON THE INSTRUCTION FOR USE MANUAL



DANGER!

It indicates a dangerous situation with risk of death for the operator.



WARNING!

It indicates a potential risk of injury for people.



CAUTION!

It indicates a caution or a remark related to important or useful functions. Pay attention to the paragraphs marked by this symbol.



NOTE

It indicates a remark related to important or useful functions.



CONSULTATION

It indicates the necessity to refer to the Instruction for Use manual before performing any procedure.

GENERAL SAFETY INSTRUCTION

Specific warnings and cautions to inform about potential damages to people and machine are shown below.

**DANGER!**

- This machine must be operated by trained and authorized personnel according to guidance of the manual.
- Before performing any cleaning, maintenance, repair or replacement procedure, read all the instructions carefully, ensure to turn the machine OFF and disconnect the battery connector.
- Do not operate the machine near toxic, dangerous, flammable and/or explosive powders, liquids or vapor. This machine is not suitable for collecting dangerous powders.
- Do not wear jewels when working near electrical components.
- Do not work under the lifted machine without supporting it with safety stands.
- When using lead (WET) batteries, they may emit inflammable gas under normal use, must keep sparks, flames, smoking materials and radiating, illuminating and burning items away from the batteries.
- When charging lead (WET) batteries, they may emit hydrogen gas which may cause explosive. Must ensure the charging environment is well ventilated and away from naked flames.

**WARNING!**

- Check the machine carefully before each use. Ensure that all the components have been well assembled before use. Or it may causes damages to people and properties.
- Before using the battery charger, ensure that the values of frequency and voltage indicated on the machine serial number label match those of mains.
- Never move the machine by pulling the battery charger cable. Do not let the cable through a closed door, or winding on sharp edges or corners. Do not run the machine on the battery charger cable. Keep the battery charger cable away from heated surfaces. Do not charge the batteries if the battery charger cable or the plug are damaged.
- To reduce the risk of fire, electric shock, or injury, make sure machine is off before leaving.
- Use or store the machine indoors in dry conditions, it is not allowed for outdoor use.
- The machine both storage and working temperature must be between 0 °C and +40 °C, the humidity of air must be between 30% - 95%.
- Do not use the machine on slopes with a gradient exceeding as specification show.
- When using and handling floor cleaning detergents, follow the instructions on the labels of the detergent bottles and wear suitable gloves and protections.
- Use brushes and pads supplied with the machine or defined in the manual. Using other brushes or pads could reduce safety.
- In case of machine malfunctions, ensure that these are not due to lack of maintenance. If necessary, request assistance from the authorized personnel or from an authorized Service Center.
- Take all necessary precautions to prevent hair, jewels and loose clothes from being caught by the machine moving parts.
- Do not use the machine in particularly dusty areas. Do not wash the machine with direct or pressured water jets, or with corrosive substances.
- Do not bump into shelves or scaffoldings, especially where there is a risk of falling objects.
- Do not lean liquid containers on the machine, use the relevant can holder.
- To avoid damaging the floor, do not allow the brush/pad to operate while the machine is stationary.
- In case of fire, use a dry powder fire extinguisher. Do not use liquid fire extinguishers.
- Do not remove or modify the machine stickers.
- Do not tamper with the machine safety guards and follow the ordinary maintenance instructions scrupulously.
- Pay attention during machine transportation when temperature is below freezing point. The water in the recovery tank and in the hoses could freeze and cause seriously damage to the machine.
- If spare parts need be replaced, order ORIGINAL spare parts from an Authorized Dealers or Retailers.

- **Return the machine to the Service Center if it doesn't work as usual or it is in condition such as damaged, placed outdoors, dropped into water.**
- **To ensure machine proper and safe operation, the scheduled maintenance shown in the relevant chapter of this Manual, must be performed by the authorized personnel or an authorized Service Center.**
- **The machine must be properly disposed of, because the presence of toxic-harmful materials (batteries, etc.), which are subject to standards that require disposal in special centers (see Scrapping chapter).**
- **This machine as a cleaning tool only, not for any other purpose use.**
- **Always keep the openings free from dust, hairs and any other foreign material which could reduce the air flow. Do not use the machine if the openings are clogged.**
- **Use the machine only where a proper lighting is provided.**
- **This machine is not intended for use by persons with reduced physical, sensory or mental capabilities, or lack of experience and knowledge, unless they have been given supervision or instruction concerning use of the machine by a person responsible for their safety.**
- **Close attention is necessary when used near children.**
- **Children should be supervised to ensure that they do not play with the machine.**
- **While using this machine, take care not to cause damage to people or objects.**

MACHINE DESCRIPTION

MACHINE STRUCTURE (as shown in Figure 1)

- | | |
|---|-------------------------------|
| 1. Recovery tank lid | 20. Brush/pad-holder |
| 2. Can holder | 21. Brush/pad-holder deck |
| 3. Handlebar | 22. Recovery water drain hose |
| 4. Control panel | 23. Solution tank |
| 5. Squeegee lifting/lowering lever | 24. Hinge |
| 6. Garden coupling | 25. Recovery tank |
| 7. Power supply cable holder | 26. Filter support |
| 8. Power cable | 27. Filler hose holder |
| 9. Solution drain and level check hose | 28. Filter cover |
| 10. Deck lifting/lowering pedal | 29. N/A |
| a) Pedal position when deck is lifted | 30. Tank cover gasket |
| b) Pedal position when deck is lowered | 31. Debris collection box (*) |
| 11. Squeegee knobs | 32. Bend tube |
| 12. Serial number plate/technical data | 33. Float ball filter |
| 13. Squeegee vacuum hose | 34. Mop and trash kit (*) |
| 14. Squeegee | 35. Solenoid valve |
| 15. Squeegee balance adjusting knob | |
| 16. Solution/clean water tap | |
| 17. Rear steering wheels | |
| 18. Solution filter | |
| 19. Front wheels on fixed axle (A).
Driving wheels (B) | |

(*): Optional

(A): Only for machine without traction

(B): Only for machine with traction

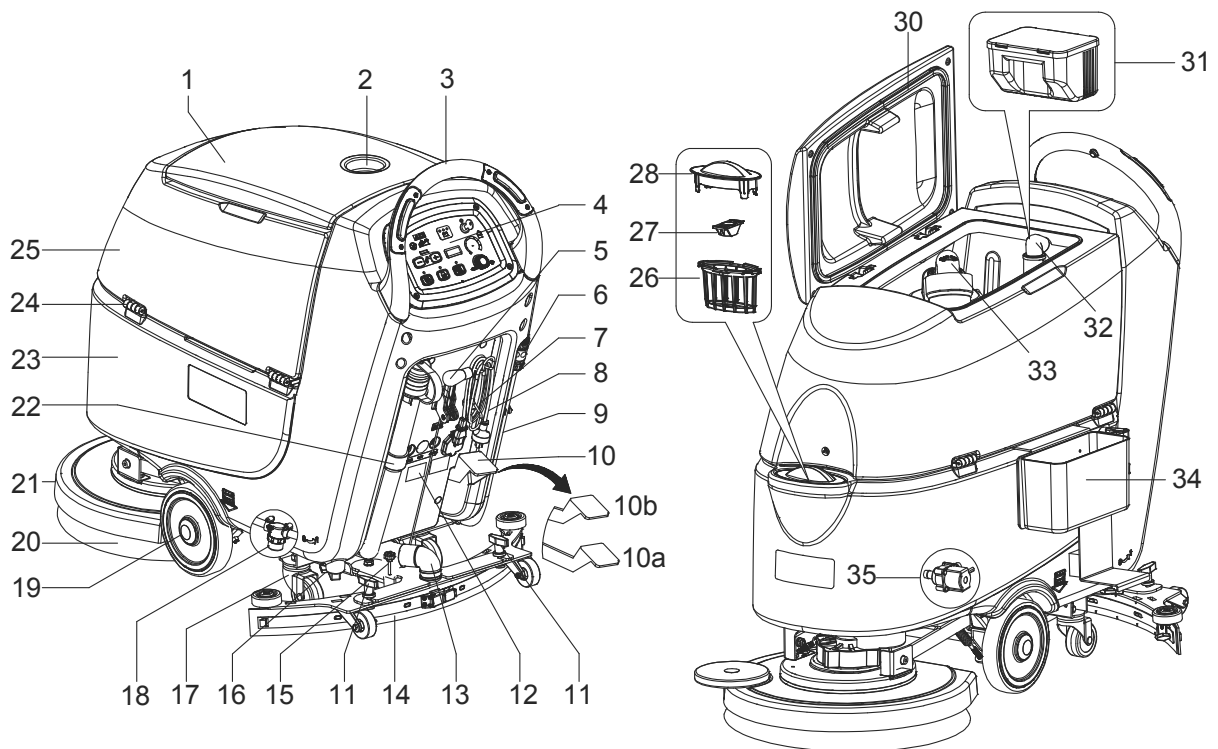

Figure 1

CONTROL PANEL (as shown in Figure 2)

- | | |
|--|---|
| 36. Machine backward switch (B) | 53. Charged battery warning light (green) |
| 37. Tank safety cable | 54. Ignition key (0 - I) |
| 38. Battery connector (red). | 55. Detergent flow control knob (**) |
| 39. Detergent tank filler plug (**) | 56. Speed adjuster (B) |
| 40. Detergent tank (**) | 57. Hour meter |
| 41. Reference table for detergent proportioning (**) | 58. Brush/pad-holder release switch |
| 42. Detergent pump (**) | 59. Vacuum system switch |
| 43. Detergent tank - pump connecting hose (**) | 60. Brush/pad-holder and vacuum system switch |
| 44. Detergent feed hose (**) | 61. Charging red LED |
| 45. Batteries | 62. Charging yellow LED |
| 46. Battery caps | 63. Charging green LED |
| 47. Flow increase switch | 64. Security cover of charging jack |
| 48. Flow decrease switch | 65. Overload protector of brush |
| 49. Solution flow indicator | 66. Overload protector of traction (B) |
| 50. Safe switch | 67. Overload protector of vacuum |
| 51. Discharged battery warning light (red) | |
| 52. Semi-discharged battery warning light (yellow) | |

(*): Optional

(**): Only for machines with Chemical Mixing System (optional)

(A): Only for machine without traction

(B): Only for machine with traction

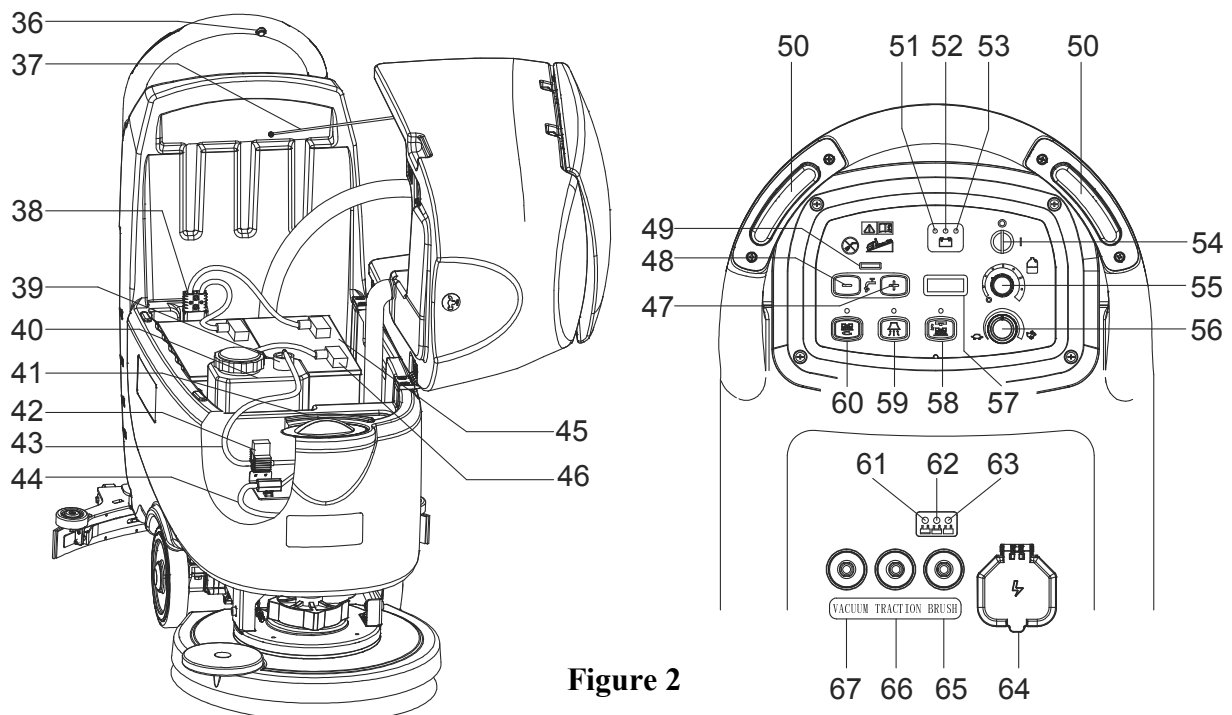

Figure 2

DISPLAY WINDOW OF CHARGER INDICATON LIGHT (as shown in Figure 2)

1. At the beginning of charging, the red LED (61) of charger normally on. It is the first stage of charging.
2. After charging some time, the red LED (61) turns off, the yellow LED (62) turns on, this is the second stage of charging.
3. After charging finish, the yellow LED (62) off, the green LED (63) turns on to indicate that the battery is fully charged.

NOTE

When charging, if the yellow LED (62) of charger is on, it may be caused by: Battery and charger does not match, battery is not connected well, or output is short-circuited.

The red LED of charger flashing may be caused by charger internal short circuit.

TECHNICAL PARAMETERS

MODEL	Units	SC530 53 B GO	SC530 53 BD GO
Packing dimensions (Lx W x H)	mm	1370x600x1300	
Machine height	mm	1080	
Machine length	mm	1260	
Machine width (without squeegee)	mm	550	
Machine weight with empty tanks (without batteries)	Kg	91	97
Gross vehicle weight (GVW)	Kg	208	214
Shipping weight	Kg	121	127
Solution tank capacity	Liter	61	
Recovery tank capacity	Liter	61	
Vacuum motor power	Watt	350	
Vacuum capacity	mm H ₂ O	1200	
Climbing capacity (Max)	%	2%	
Front wheel diameter	mm	200	
Rear wheel diameter	mm	76	
Sound level	dB(A)	69±3	
Solution/water Flow	CL/M	0 – 240	
Working width	MM	530	
Squeegee width	MM	760	
Brush/pad diameter	MM	530/508	
Brush motor power	Watt	450	
Brush speed	Rpm	150	
Brush/pad pressure(Max)	Kg	27	23
Drive motor power	Watt	/	150
Working speed	Km/h	/	0-4.5
Voltage	V	24V	
Battery	Ah	12V 105 Ah C5	
Battery charger	V/A	24V/13A	
Battery compartment size (L x W x H)	mm	350X350X300	

WIRING DIAGRAM (MACHINE WITHOUT TRACTION)

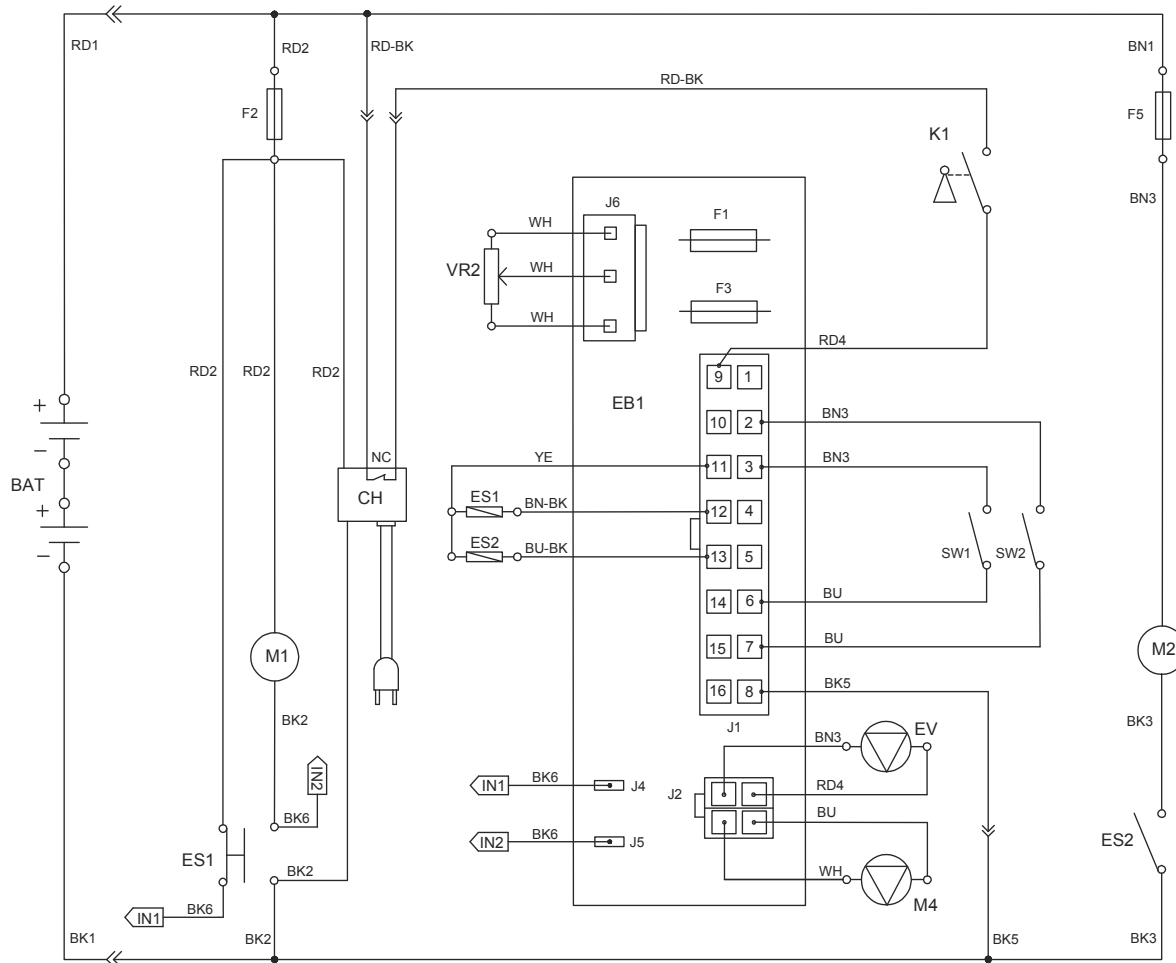

COMPONENTS		
Key	CODE	Description
BAT	N/A	24V BATTERIES
CH	VS10204	BATTERY CHARGER
EB1	VS13201	CONTROL PANEL BOARD
ES1	9095127000	ELECTROMAGNETIC SWITCH 24V (BRUSH MOTOR)
ES2	VS10201	RELAY 24V (VACUUM MOTOR)
F1	VS13208	LOW POWER CIRCUIT FUSE
F2	ZD48320	CIRCUIT BREAKER (BRUSH MOTOR)
F3	VS13209	BRUSH RELEASE FUSE
F5	ZD48320	CIRCUIT BREAKER (VACUUM MOTOR)
K1	9100001354	KEY SWITCH
M1	VS10702	BRUSH MOTOR
M2	VF90520	VACUUM MOTOR
M4	VF90282	SOLENOID VALVE
M5	N/A	DETERGENT PUMP (**)
SW1	VS10202	SAFETY SWITCH (BRUSH)
SW2	VS10202	SAFETY SWITCH (BRUSH)
VR2	N/A	DETERGENT PUMP POTENTIOMETER (**)

WIRE ROD	
RD1	RED/6AWG
RD2	RED/10AWG
RD4	RED/20AWG
BK1	BLACK/6AWG
BK2	BLACK/10AWG
BK3	BLACK/12AWG
BK5	BLACK/20AWG
BK6	BLACK/16AWG
RD-BK	RED-BLACK/20AWG
BN1	BROWN/12AWG
BN3	BROWN/20AWG
BN-BK	BROWN-BLACK/20AWG
BU	BLUE/20AWG
BU-BK	BLUE-BLACK/20AWG
YE	YELLOW/20AWG
WH	WHITE/20AWG

(**) = For machines with Chemical Mixing System (Optional)

WIRING DIAGRAM (MACHINE WITH TRACTION)

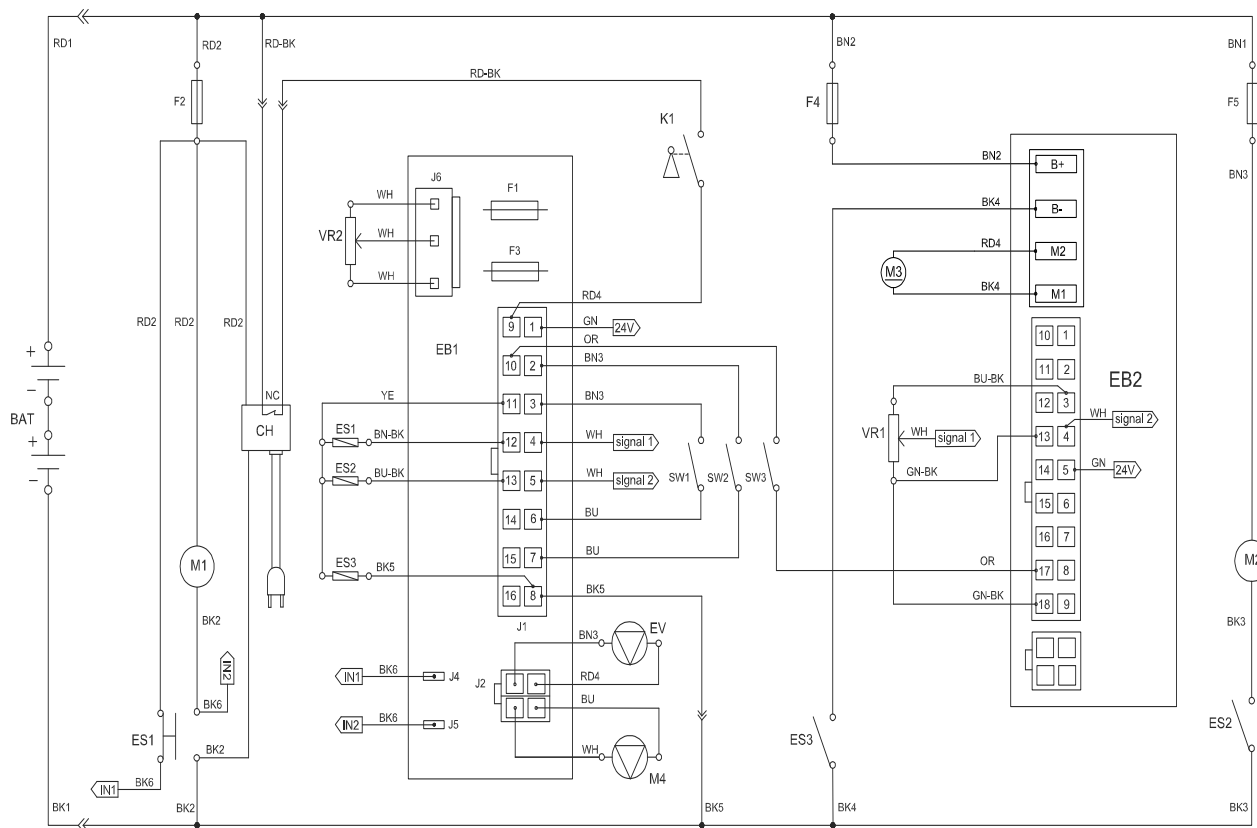

COMPONENTS		
Key	CODE	Description
BAT	N/A	24V BATTERIES
CH	VS10204	BATTERY CHARGER
EB1	VS13201	CONTROL PANEL BOARD
EB2	VS10209	ELECTRONIC BOARD (TRACTION SYSTEM)
ES1	9095127000	ELECTROMAGNETIC SWITCH 24V (BRUSH MOTOR)
ES2	VS10201	RELAY 24V (VACUUM MOTOR)
ES3	VS10201	RELAY 24V (TRACTION SYSTEM)
F1	VS13208	LOW POWER CIRCUIT FUSE
F2	ZD48320	CIRCUIT BREAKER (BRUSH MOTOR)
F3	VS13209	BRUSH RELEASE FUSE
F4	VF99012	CIRCUIT BREAKER (TRACTION SYSTEM)
F5	ZD48320	CIRCUIT BREAKER (VACUUM MOTOR)
K1	9100001354	KEY SWITCH
M1	VS10702	BRUSH MOTOR
M2	VF90520	VACUUM MOTOR
M3	VS11702	DRIVE MOTOR
M4	VF90282	SOLENOID VALVE
M5	N/A	DETERGENT PUMP (**)
SW1	VS10202	SAFETY SWITCH (BRUSH/TRACTION)
SW2	VS10202	SAFETY SWITCH (BRUSH/TRACTION)
SW3	VS10202	REVERSING SWITCH
VR1	VS10213	SPEED POTENTIOMETER
VR2	N/A	DETERGENT PUMP POTENTIOMETER (**)

WIRE ROD	
RD1	RED/6AWG
RD2	RED/10AWG
RD4	RED/20AWG
BK1	BLACK/6AWG
BK2	BLACK/10AWG
BK3	BLACK/12AWG
BK4	BLACK/14AWG
BK5	BLACK/20AWG
BK6	BLACK/16AWG
RD-BK	RED-BLACK/20AWG
GN	GREEN/20AWG
GN-BK	GREEN-BLACK/20AWG
BN1	BROWN/12AWG
BN2	BROWN/14AWG
BN3	BROWN/20AWG
BN-BK	BROWN-BLACK/20AWG
BU	BLUE/20AWG
BU-BK	BLUE-BLACK/20AWG
OR	ORANGE/20AWG
YE	YELLOW/20AWG
WH	WHITE/20AWG

(**) = For machines with Chemical Mixing System (Optional)

OPERATING GUIDE



WARNING!

On some points of the machine there are some adhesive plates indicating:

- DANGER!
- WARNING!
- CAUTION!
- CONSULTATION

While reading this Manual, the operator must pay particular attention to the symbols shown on the plates. Do not cover these plates for any reason and immediately replace them if damaged.

BATTERY CHECK/SETTING ON A NEW MACHINE



WARNING!

The electric components of the machine can be seriously damaged if the batteries are either improperly installed or connected. The batteries must be installed by qualified personnel only. Set the function electronic board and the built-in battery charger according to the type of batteries used (WET or GEL/AGM batteries). Check the batteries for damage before installation. Disconnect the battery connector (38) and the battery charger plug (8). Handle the batteries with great care. Install the battery terminal protection caps supplied with the machine.



NOTE

The machine requires two 12 V batteries, connected according to the diagram (Figure. 3).

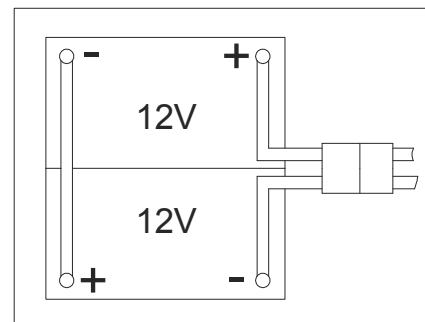

Figure 3

The machine can be supplied in one of the following modes:

A) Batteries (WET or GEL/ AGM) already installed and charged

1. Check that the batteries are connected to the machine with the connector (38).
2. Insert the ignition key (54) and turn it to "I". If the green warning light (53) turns on, the batteries are fully charged. If the yellow (52) or red warning light (51) turns on, the batteries must be charged (see the procedure in Maintenance chapter).

B) Without batteries

1. Buy appropriate batteries (see the Technical Data paragraph).
2. For battery choice and installation, apply to qualified battery Retailers.
3. Set the machine and the battery charger according to the type of batteries (WET or GEL/ AGM), as shown in the next paragraph.

BATTERY INSTALLATION AND BATTERY TYPE SETTING (WET OR GEL/ AGM)

According to the type of batteries (WET or GEL/AGM), set the machine and electronic board of the battery charger as follows:

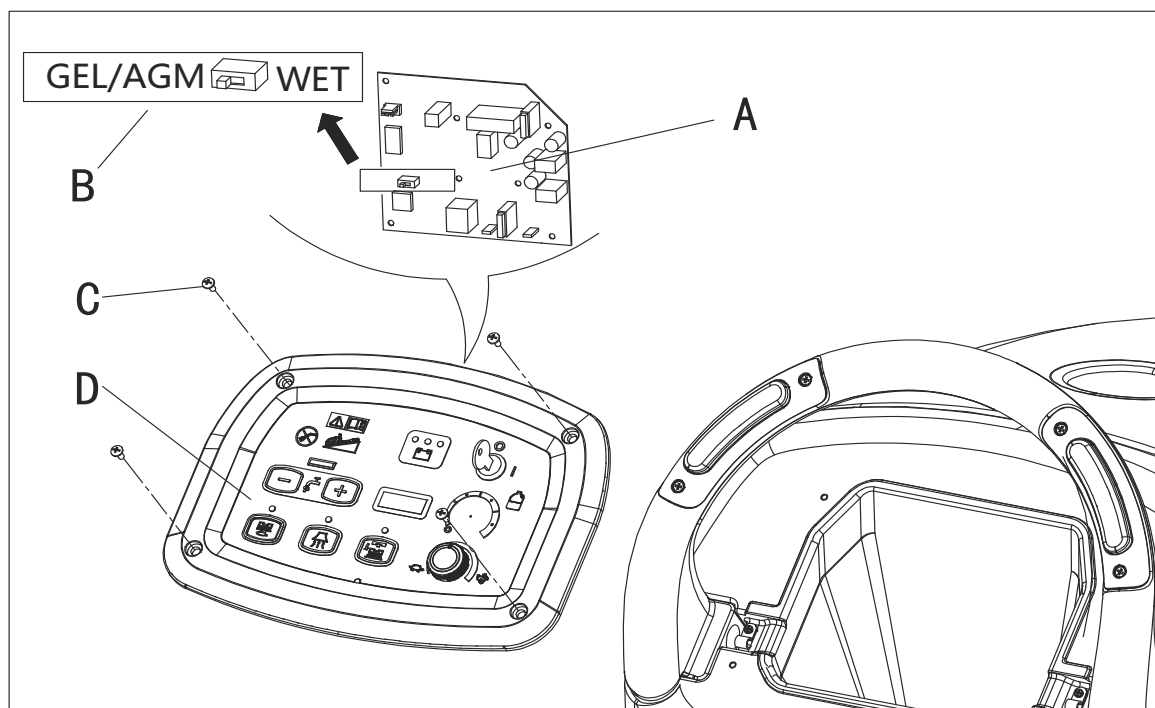

Figure 4

Machine setting

- Turn the ignition key (54) to "I" and in the very first seconds of machine operation pay attention to the following:
 - If the green warning light (53) is flashing, the machine is set to GEL/AGM.
 - If the red warning light (51) is flashing, the machine is set to WET.
- If the setting need to be changed, perform the following procedure..
- The factory setting is for GEL/AGW batteries. If the setting correspond to the battery installation, go to step7 directly. Otherwise, follow next steps4~6.
- Remove the screws on control panel (C, Figure 4), then turn over the PCB (A, Figure 4) to find the DIP switch (B,Figure4) for setting battery type(WET or GEL/AGM).
- Turn the DIP switches to "WET" position for wet batteries installed.
- If the setting complete to the battery option. Install the screws on control panel.

Battery installation

- Open the recovery tank cover (1) and check that the recovery tank (25) is empty; otherwise empty it with the drain hose. (22)
- Close the recovery tank cover (1).
- Overturn the recovery tank (25) carefully.
- The machine is supplied with cables suitable to install 2×12 V batteries. Carefully put the batteries into the compartment, then install them correctly.
- Route and install the battery cable as shown in (Figure3), then carefully tighten the nut on each battery terminal.
- Place the protection cap on each terminal, then connect the battery connector (38).
- Carefully lower the recovery tank (25).

Battery charging

- Charge the batteries. (See procedures in maintenance chapter).

BRUSH/PAD-HOLDER INSTALLATION AND UNINSTALLATION

**NOTE**

Install either the brush (A, Figure 5) or pad-holder (B and C, Figure 5) according to the type of floor to be cleaned.

**CAUTION!**

Before installation or uninstallation of brush or pad-holder, make sure all the switches on machine are in off position and lifting up the squeegee from the floor. The operator must be equipped with suitable personnel protection devices such as gloves to reduce the risk of accidents.

Proceed as following:

1. Insert the ignition key (54) and turn it to "O".
2. Lift the deck by pressing the pedal (10).
3. If equipped, turn the speed adjuster (56) to idle by turning it counter-clockwise.
4. Place the brushes (A, Figure. 5) or the pad-holder (B) under the deck (21).
5. Lower the deck on the brushes/pad-holders by pressing the pedal (10).
6. Turn the ignition key (54) to "I".
7. Press the Brush/pad-holder and vacuum system switch (60).
8. Press one of the safe switch (50) to engage the brush/pad-holder, then release it. If necessary, repeat the procedure until the brushes/pad-holders are engaged.

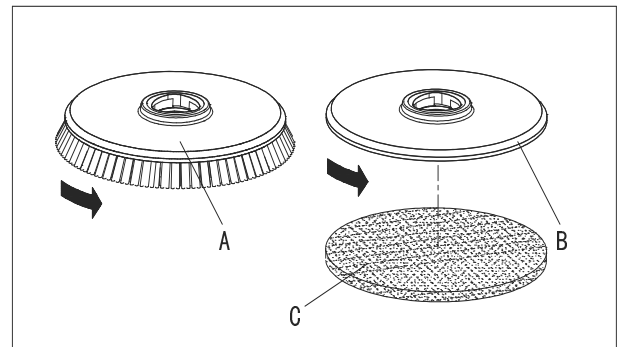

Figure 5

**WARNING!**

(Only for machine with traction): Turn the speed adjuster (56) counter-clockwise to drive the machine at the minimum speed.

Slightly press the safe switch (50), otherwise the machine starts to move.

To engage the safe switch (50) which turns on the brush/pad-holder motor.

9. To remove the brush/pad-holder lift the deck by pressing the pedal (10), then press the switch (58), the brush/pad-holder will be removed.

ADJUSTING THE BALANCE OF SQUEEGEE

1. Install the squeegee and screw up the nut (H), then connect the vacuum hose (G) to the squeegee.
2. Adjust the squeegee by squeegee adjusting handle (A, Figure 6).
 - a) If there is gap between the ground and middle section of rear squeegee blade (B), adjust the knob (A) in counterclockwise direction (F) until all section of rear squeegee blade good contact with ground, the front blade touch the ground slightly.
 - b) If there is gap between the ground and both end section of rear blade (C and D), adjust the knob (A) in clockwise direction (E) until all section of rear blade good contact with the ground, the front blade touch the ground slightly.

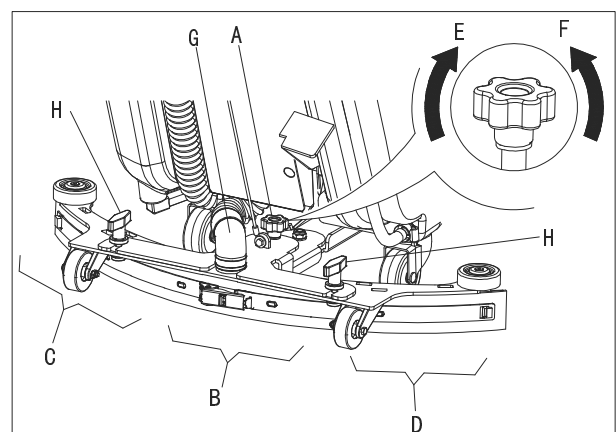

Figure 6

SOLUTION OR WASHING WATER TANK FILLING

**NOTE**

If the machine is equipped with Chemical Mixing System (optional) the tank must be filled with clean water, otherwise the tank can be filled with solution.

1. Open the filler neck (B, Figure.7).
2. (For machines without Chemical Mixing System) Use the front filler neck (B) and the rear filler neck (H) to fill the tank (D) with a solution suitable for the work to be performed. Refill to the reference mark "1" of the level check hose (H). Always follow the dilution instructions on the label of the chemical product used to prepare the solution. The solution temperature must not exceed +104°F (+40°C).

**WARNING!**

Use only low-foam and non-flammable detergents, intended for automatic scrubber applications.

3. (For machines with Chemical Mixing System) Fill the tank (D) with clean water by using the filler neck (B) and the rear filler neck (H). Refill to the reference mark "1" of the level check hose (H). The water temperature must not exceed +104°F (+40°C).

DETERGENT TANK FILLING (FOR MACHINES WITH CHEMICAL MIXING SYSTEM)

1. Open the cover (E) and check that the recovery tank (F) is empty, otherwise empty it with the drain hose (G).
2. Carefully overturn the recovery tank (A, Figure. 8).
3. Open the cap (B).
4. Replace or fill the jug (C) with any standard gallon container of detergent suitable for the work to be performed (highly concentrated detergents). Do not fill the detergent tank completely, leave a few centimeters from the edge.

**WARNING!**

Use only low-foam and non-flammable detergents, intended for automatic scrubber applications.

**NOTE**

To install a new jug container, determine the cap size and if it is the smaller cap, remove the reducing adapter from the hose cap (B). Insert the suction tube into the jug (C). Pushdown firmly on the cap (B) and twist at the same time to put the cap back onto the jug (C). In case of new system, system emptied for cleaning, etc., wait for the hoses to fill up, before starting the Chemical Mixing System.

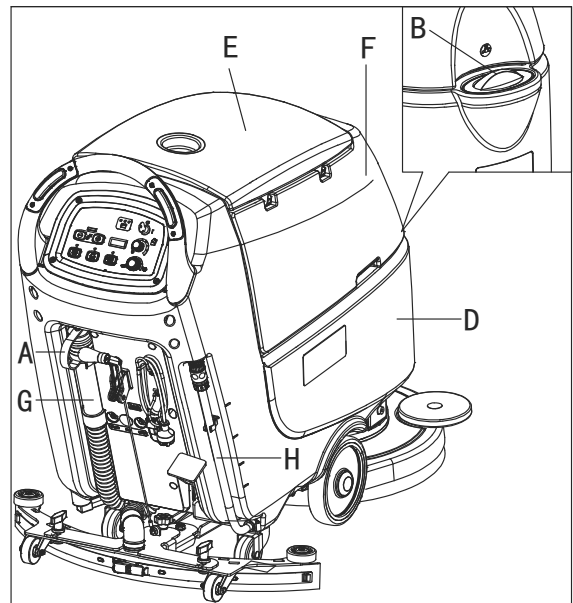

Figure 7

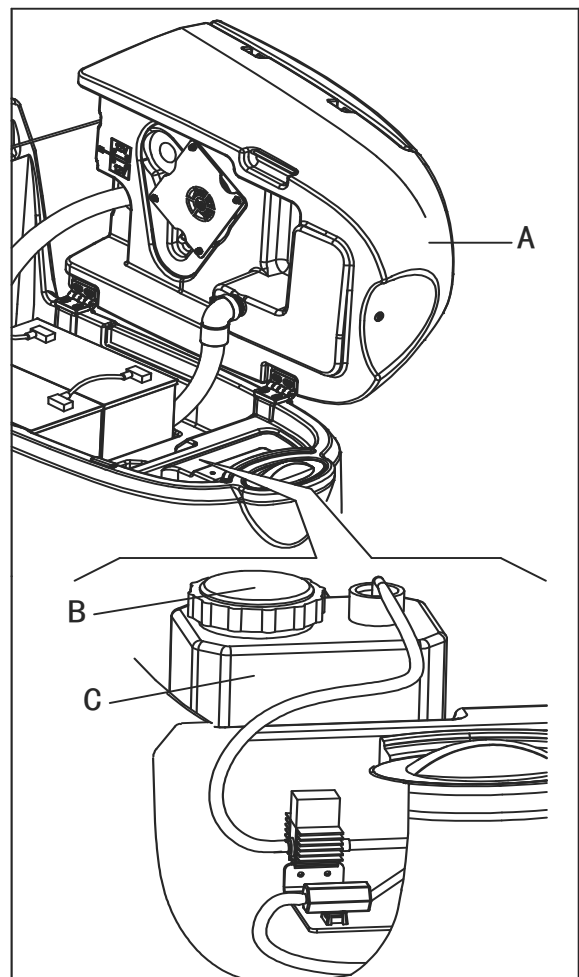

Figure 8

MACHINE START AND STOP

Starting the machine

1. Prepare the machine as shown in the previous paragraph.
2. Insert the ignition key (A, Figure. 9) and turn it to "I". Check that the green warning light (B) turns on (charged battery). If the yellow (C) or red warning light (D) turns on, turn the ignition key back to "0" and charge the batteries (see the procedure in Maintenance chapter).
3. Drive the machine to the working area:
 - By pushing it with the hands on the handlebar (E) (only for machine without traction).
 - By pushing it with the hands on the handlebar (E) and pressing the switch (F) to move forward, or pressing the switch (F) together with the switch (G) to move backward (only for machine with traction). The forward speed can be adjusted with the adjuster (H).
4. Lower the squeegee (I) with the lever (J).
5. Lower the brush/pad-holder deck (K) by lifting the pedal (L).
6. Press the brush/pad-holder switch (M) and the vacuum system switch (N).
7. Press the washing water flow control switches (O) as necessary, depending on the type of cleaning to be performed.
8. Start cleaning:
 - (only for machine without traction) by pushing the machine with the hands on the handlebar (E) and pressing the switch (F).
 - (only for machine with traction) by pushing the machine with the hands on the handlebar (E) and by pressing the switch (F). If necessary, the forward speed can be adjusted with the adjuster (H).



NOTE

To move the machine forward, press either the left or right switch (F) or both.

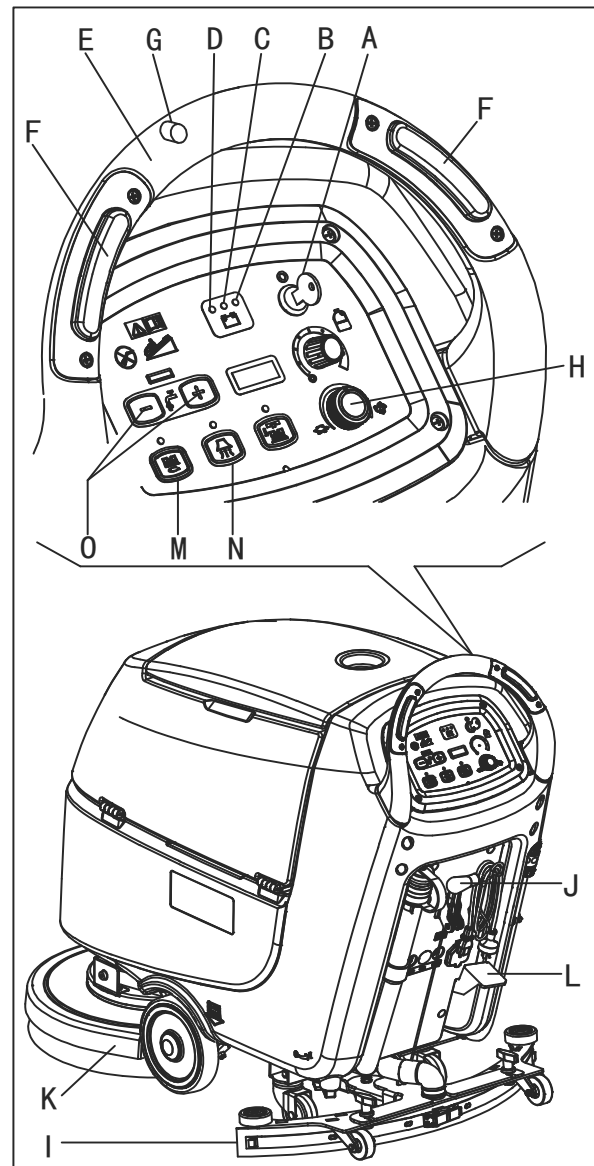

Figure 9

Stopping the machine

9. Stop the machine by using the handlebar (E) (only for machine without traction). Stop the machine by releasing the switches (F) (only for machine with traction).
10. Stop the brushes and the vacuum system by pressing the switch (M). The vacuum system stops after a few seconds.
11. Lift the brush/pad-holder deck (K) by pressing the pedal (L).
12. Lift the squeegee (I) with the lever (J).
13. Turn the ignition key (A) to "0".
14. Make sure that the machine cannot move independently.

MACHINE OPERATION (SCRUBBERING AND DRYING)

1. Start the machine as shown in previous paragraphs.
2. While keeping both hands on the handlebar press the safety switch (F, Figure. 9), then maneuver the machine and start scrubbing/drying the floor.
3. If necessary, stop the machine then adjust squeegee according to section “Adjusting balance of squeegee”.

**NOTE**

For correct scrubbing/drying of floors at the sides of the walls, Suggests to go near the walls with the right side of the machine (A and B, Figure. 10) as shown in the figure.

**CAUTION!**

To avoid any damage to the floor surface, turn off the brushes/pad-holders when the machine stops in one place.

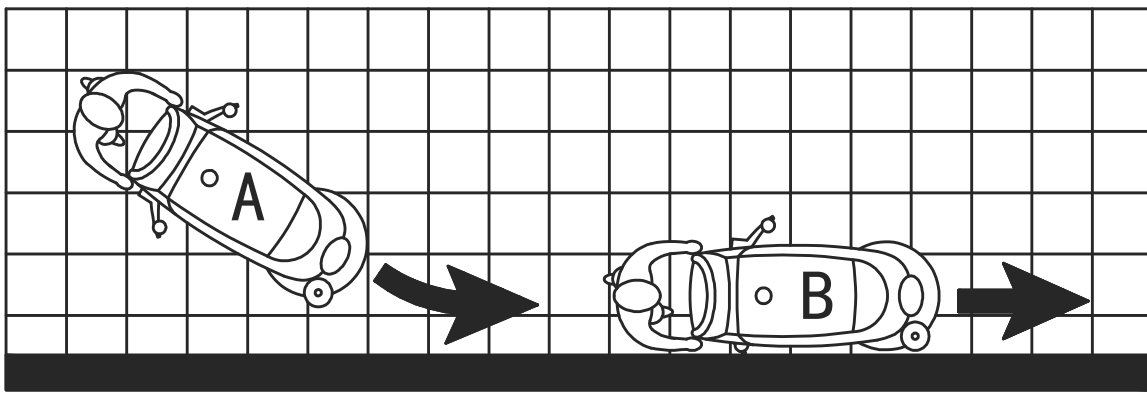

Figure 10

Detergent flow adjustment**(For machines with Chemical Mixing System)**

1. Turn the knob (A, Figure. 11) clockwise or counter-clockwise to increase or decrease the detergent concentration.
2. The average detergent concentration values, matching the 4 colored areas of the scale (B), are shown in the figure.
3. To set the detergent quantity to zero, fully turn the knob (A) counter-clockwise.

**NOTE**

The detergent concentration is kept constant even if the washing water flow is changed with the switches (C) or (D).

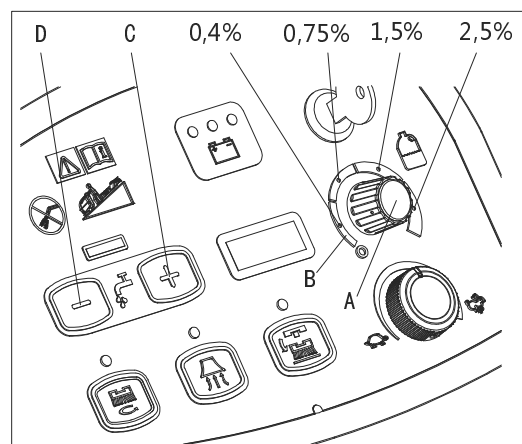

Figure 11

Battery discharge during operation

Until the green warning light (A, Figure. 12) stays on, the batteries allow the machine to work normally. When the green warning light (A) turns off, and the yellow warning light (B) turns on, it is advisable to charge the batteries, because the remaining charge will last for a few minutes (depending on battery characteristics and work to be performed). When the red warning light (C) turns on, batteries are fully discharged. After a few seconds, the brush/pad-holder is automatically tuned off, while (only for machine with traction) the drive system stay on, to finish drying the floor and drive the machine to the appointed recharging area.



CAUTION!

Do not use the machine with discharged batteries, to avoid damaging the batteries and reducing the battery life.

TANK EMPTYING

An automatic float shut-off system (A, Figure. 13) blocks the vacuum system when the recovery water tank (B) is full. The vacuum system deactivation is signaled by a sudden increase in the vacuum system motor noise frequency, also the floor has not dried.



CAUTION!

If the vacuum system turns off accidentally (for example, when the float is activated because of a sudden machine movement), to resume the operation: turn off the vacuum system by pressing the switch (D, Figure. 12), then open the cover (C, Figure. 13) and check that the float inside the grid (A) has gone down to the water level. Then close the cover (C) and turn on the vacuum system by pressing the switch (D, Figure. 12).

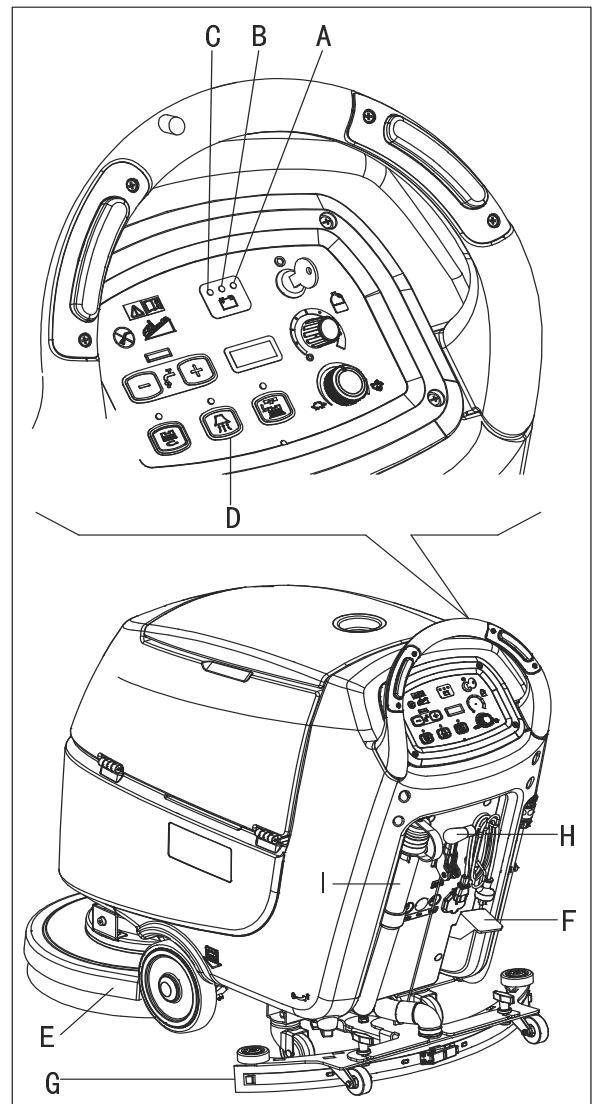

Figure 12

When the recovery water tank (B, Figure. 13) is full, empty it according to the following procedure.

Recovery water tank emptying

1. Stop the machine.
2. Lift the brush/pad-holder deck (E, Figure.12) by pressing the pedal (F).
3. Lift the squeegee (G) with the lever (H).
4. Drive the machine to the appointed disposal area.
5. Empty the recovery water tank with the hose (I). Then, rinse the tank (B, Figure. 13) with clean water.

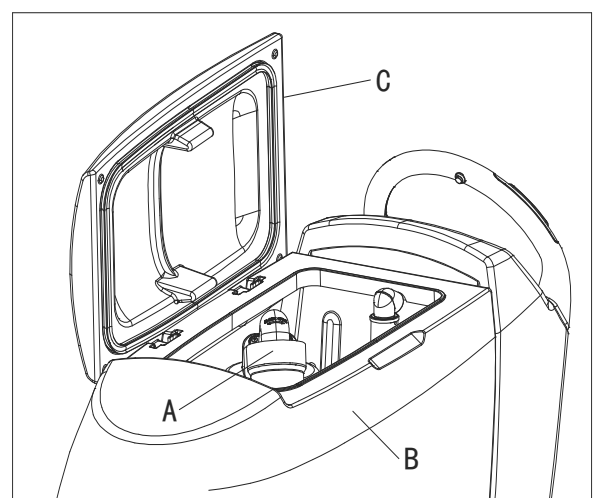

Figure 13

**CAUTION!**

When draining the wastewater, the vacuum tube for waste must be folded (A, Figure. 14) and lowered to a lower position (B, Figure. 14), and then open the lid of the vacuum tube for waste to drain the water. Do not make the outlet of the vacuum tube for waste face upward to drain the water vertically. This is to avoid wastewater spilling onto the operator.

6. Perform steps 1 to 4.

Solution/clean water tank emptying

7. Empty the solution tank with the hose (A, Figure. 15). After working, rinse the tank with clean water.

AFTER USING THE MACHINE

After working, before leaving the machine:

1. Remove the brushes/pad-holders.
2. Empty the tanks (B and C, Figure. 15) as shown in the previous paragraph.
3. Perform the daily maintenance procedures (see the Maintenance chapter).
4. Store the machine in a clean and dry place, with the brushes/pad-holders and the squeegee lifted or removed.

MACHINE LONG INACTIVITY

If the machine is not going to be used for more than 30 days, proceed as follows:

1. Perform the procedures shown in After Using the machine paragraph.
2. Disconnect the battery connector (38).

FIRST PERIOD OF USE

After the first 8 hours, check the machine fastening and connecting parts for proper tightening and check the visible parts for wear and leakage.

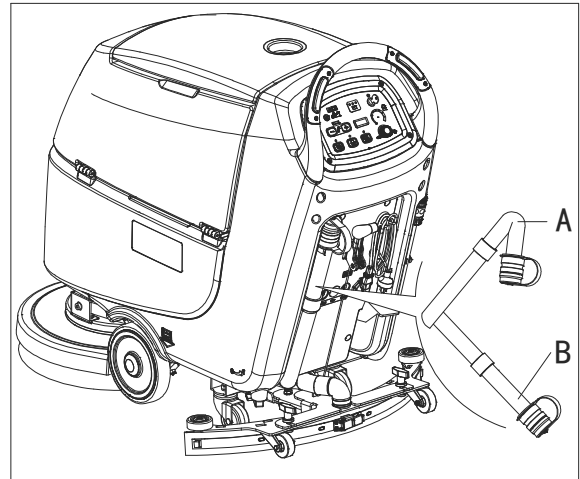

Figure 14

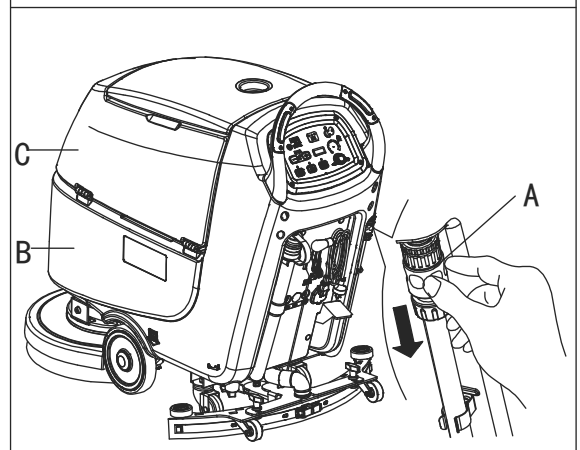
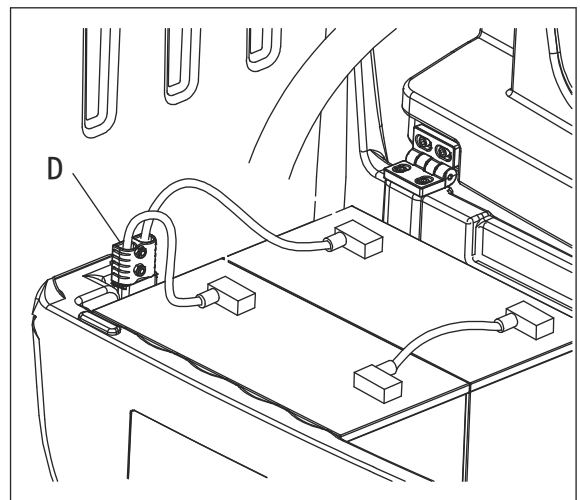

Figure 15

MAINTENANCE



WARNING!

Maintenance procedures must be performed after the machine is turned off and the battery charger cable is disconnected. In addition, carefully read the safety chapters in the manual.

All scheduled or extraordinary maintenance procedures must be performed by qualified personnel or an authorized Service Center. This manual only describes the general and common maintenance procedures.

For other maintenance procedures that are not in below maintenance schedule table, please refer to the Service Manual that can be consulted at any our company Service Center.

SCHEDULED MAINTENANCE TABLE



CAUTION!

The procedure marked with (1) must be performed when the machine is used after 9 hours for the first time. The procedure marked with (2) must be done by Service Center that qualified by our company.

Procedure	Daily, after each use	Weekly	semiannually	Yearly
Battery charging				
Squeegee cleaning				
Brush/Pad-holder cleaning				
Tank cleaning				
Tank sealing strip inspection				
Float ball filter cleaning				
Squeegee blade check and replacement				
Cleaning water filter cleaning				
Suction filter cleaning				
WET battery fluid level check				
Screw and nut tightness inspection			(1)	
Brush/Pad-holder carbon brush check or replacement				(2)
Suction motor carbon brush check or replacement				(2)
Drive system motor carbon brush check or replacement (only for machine with traction)				(2)

BATTERY CHARGING



NOTE

Charge the batteries when the yellow (G, Figure. 16) or red warning light (H) turns on, or when finishing cleaning.



CAUTION!

Keeping the batteries charged make their life last longer.



CAUTION!

When the batteries are discharged, charge them as soon as possible, as that condition makes their life shorter. Check for battery charge at least once a week.



WARNING!

WET battery charging produces highly explosive hydrogen gas. Charge the batteries in well-ventilated areas and away from naked flames. Do not smoke while charging the batteries. Keep the tank open while charging the batteries.



WARNING!

Pay careful attention when charging the batteries as there may be battery fluid leakages. The battery fluid is corrosive. If it comes in contact with skin or eyes, rinse thoroughly with water and consult a physician.

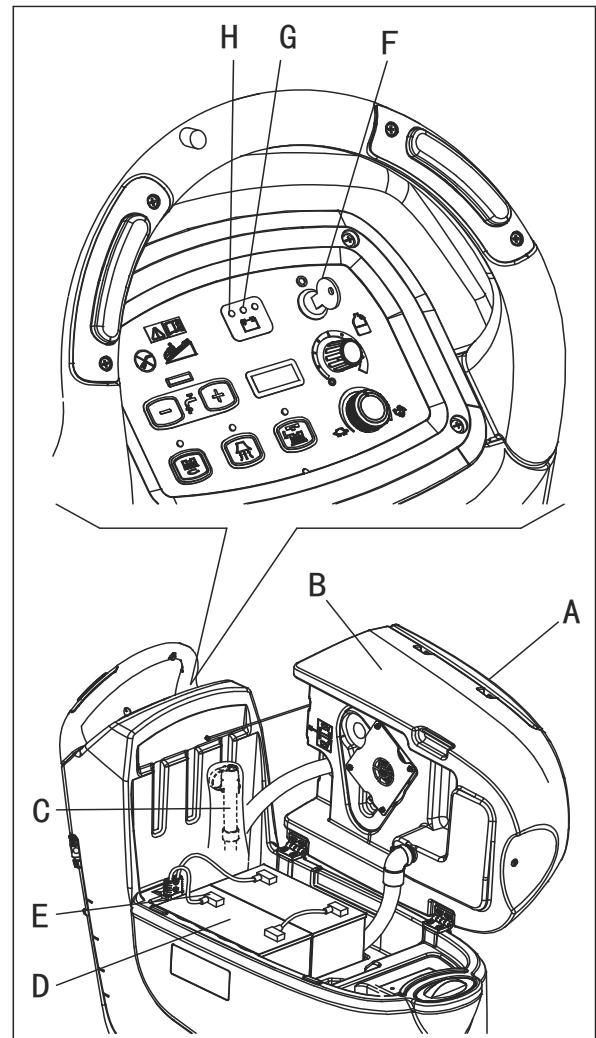

Figure 16

Preliminary procedures

1. Open the cover (A, Figure. 16) and check that the recovery water tank (B) is empty, otherwise empty it with the drain hose (C).
2. Drive the machine on a level floor.
3. Turn the ignition key (F) to "0".
4. Carefully lift the tank (B).
5. For WET batteries only:
 - Check the level of electrolyte inside the batteries (D); if necessary, top up through the caps (E).
 - Leave all the battery caps (E) open for next charging.
 - If necessary, clean the upper surface of the batteries (D).
6. Charge the batteries according to the following procedure.

Battery charging with battery charger installed on the machine

7. Connect the battery charger cable (A, Figure. 17) to the electrical mains (G) (the electrical mains voltage and frequency must be compatible with the battery charger values shown on the machine serial number plate (F)). When the battery charger is connected to the electrical mains, all machine functions are automatically cut off. If the red warning light (B) on the battery charger control panel stays on, the battery charger is charging the batteries.
8. When the green warning light (C) turns on, the battery charging is completed.
9. When the battery charging is completed, disconnect the battery charger cable (A) from the electrical mains (G) and wind it round its housing (D).
10. Carefully lower the tank.



NOTE

For further information about the operation of the battery charger (E, Figure. 17), see the relevant Manual.

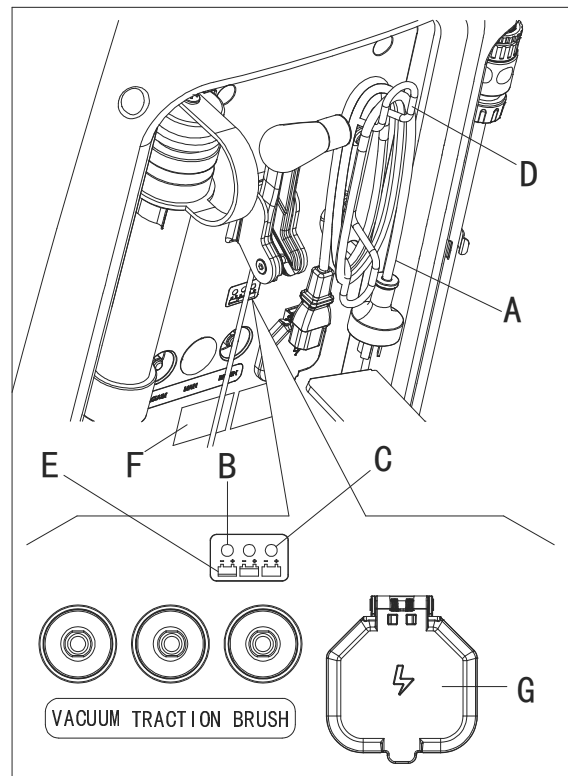

Figure 17

BRUSH/PAD CLEANING



CAUTION!

It is advisable to use protective gloves when cleaning the brush/pad because there may be sharp debris.

1. Remove the brush/pad from the machine, as shown in the Use chapter.
2. Clean and wash the brush/pad with water and detergent.
3. Check that the brushes/pads are in working condition and not excessively worn; if necessary replace them.

SOLUTION FILTER CLEANING

1. Drive the machine on a level floor.
2. Ensure that the machine is off and the ignition key (54) has been removed.
3. Close the solution tap (A, Figure. 18) under the machine, behind the right rear wheel. The tap (A) is closed when it is on the position (B) and it is open when it is on the position (C).
4. Remove the transparent cover (D), then remove the filter strainer (E). Clean and install them on the support (F).



NOTE

The filter strainer (E) must be correctly positioned on the housing (H) of the support (F).

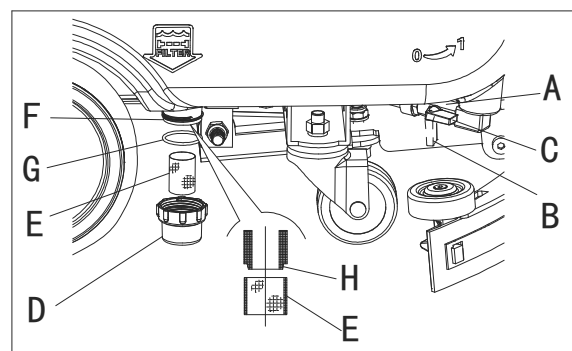

Figure 18

5. Open the tap (A).

SQUEEGEE CLEANING

**NOTE**

The squeegee must be clean and its blades must be in good conditions in order to get a good drying

**CAUTION!**

It is advisable to wear protective gloves when cleaning the squeegee because there may be sharp debris.

1. Drive the machine on a level floor.
2. Turn the ignition key (A, Figure. 19) to "0".
3. Lower the squeegee (B) with the lever (C).
4. Loosen the knobs (D) and remove the squeegee (B).
5. Disconnect the vacuum hose (E) from the squeegee.
6. Clean the steel or the aluminum squeegee (Figure. 20). Clean the compartments (A) and the hole (B) especially. Check the front blade (C) and the rear blade (D) for integrity, cuts and tears; if necessary replace them (see the procedure in the following paragraph).
7. Assemble the squeegee in the reverse order of disassembly.

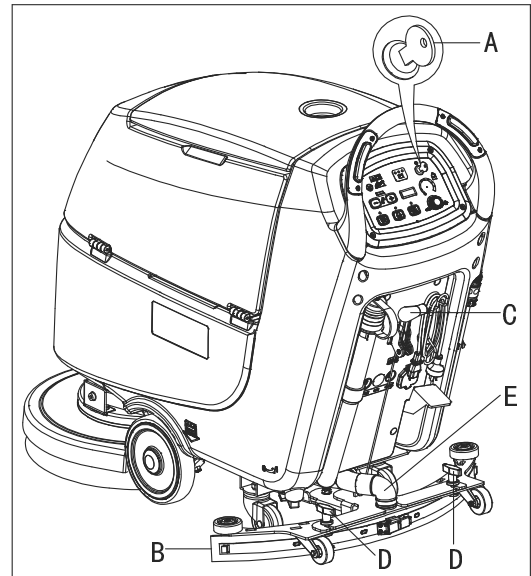

Figure 19

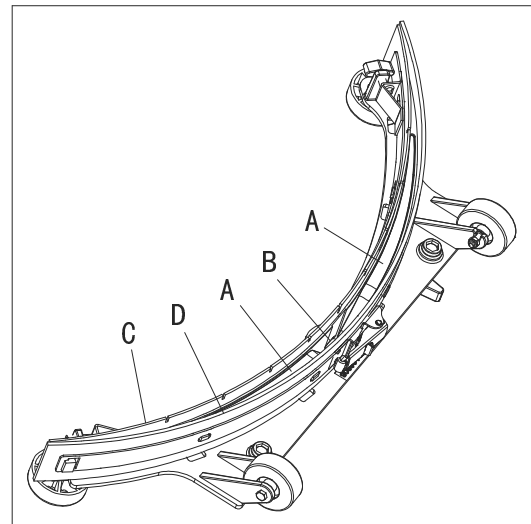

Figure 20

SQUEEGEE BLADE CHECK AND REPLACEMENT

1. Clean the steel or the aluminum squeegee, as shown in the previous paragraph.
2. Check that the edges (E, Figure. 22) of the front blade (C) and the edges (F) of the rear blade (D) lay down on the same level, along their length; if necessary adjust their height according to the following procedure:
 - Remove the tie rod (G), disengage the fasteners (M) and adjust the rear blade (D), then engage the fasteners (M) and install the tie rod (G).
 - Loosen the knobs (I) and adjust the front blade (C), then tighten the knobs.
3. Check the front blade (C) and rear blade (D) for wear, cuts and tears; if necessary replace them according to the following procedure. Check that the front corner (J) of the rear blade (D) is not worn; if necessary, overturn the blade to replace the worn corner with an integral one. If the other corners are worn too, replace the blade according to the following procedure:
 - Remove the tie rod (G), disengage the fasteners (M) and remove the retaining strip (K), then replace/overturn the rear blade (D). Assemble the blade in the reverse order of disassembly.
 - Unscrew the knobs (I) and remove the retaining strip (L), then replace the front blade (C). Assemble the blade in the reverse order of disassembly. After the blade replacement (or overturning), adjust the height as shown in the previous step.
4. Connect the vacuum hose (A, Figure. 21) to the squeegee.
5. Install the squeegee (B) and screw down the knobs (C).
6. If necessary, adjust the squeegee balance adjusting knob (D).

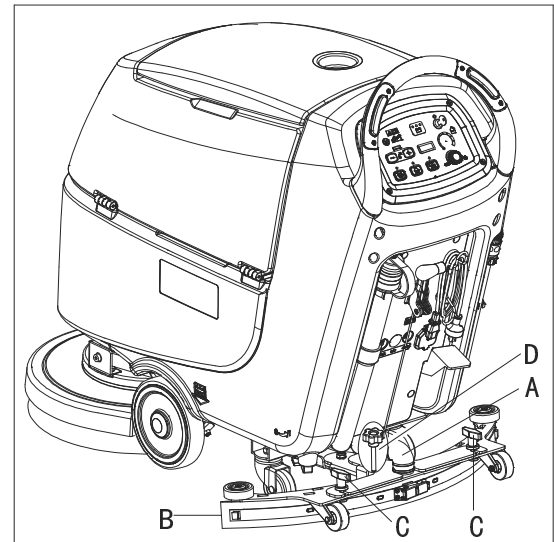

Figure 21

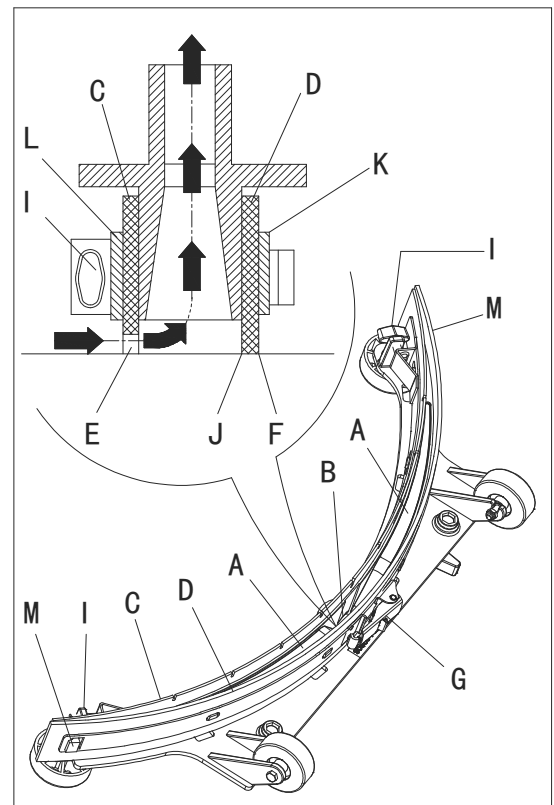

Figure 22

TANK AND VACUUM GRID WITH FLOAT CLEANING, AND COVER GASKET CHECK

1. Drive the machine on a level floor.
2. Ensure that the machine is off and the ignition key (54) has been removed.
3. Turn the recovery tank lid (A, Figure23) 90 degree position where it can be took off from the tank, and then take down the float ball filter (P) from the tank.
4. Clean the recovery tank lid (A), recovery tank (B), clean water tank(C) and the float ball filter support frame (E). Empty the recovery tank with the drain hose (22).
5. If necessary, follow the symbols “OPEN” and “CLOSE” as shown in (Figure23) to open the bottom cover (F) of float ball filter and then clean the float ball (D), filter support frame (E) and filter sponge (I). After cleaning, fix the float ball (D) into the filter support frame (E) and then align the mark groove (L) of the bottom cap (F) of the float ball filter with the mark groove (L) of the float filter support frame (E).Screw the bottom cap of the float ball filter tight, and fix the filter sponge (I) onto the float filter support frame (E). Finally, connect it to the sewage suction hose (M).
6. Inspect the integrity of the tank sealing strip.

**NOTE**

Tank sealing strip (G) makes to produce the vacuum inside the tank when suction motor works. The tank must be sealed can effectively absorb the water from the ground to recovery tank.

7. Check whether the contact surface of sealing strip (G) is integrity and sealing is sufficient. If necessary, take the sealing strip of the tank out of the groove (H) and replace it. Assembly the new sealing strip as shown in (Figure23), the joint should be back in the middle area.
8. Close the recovery tank lid (A).

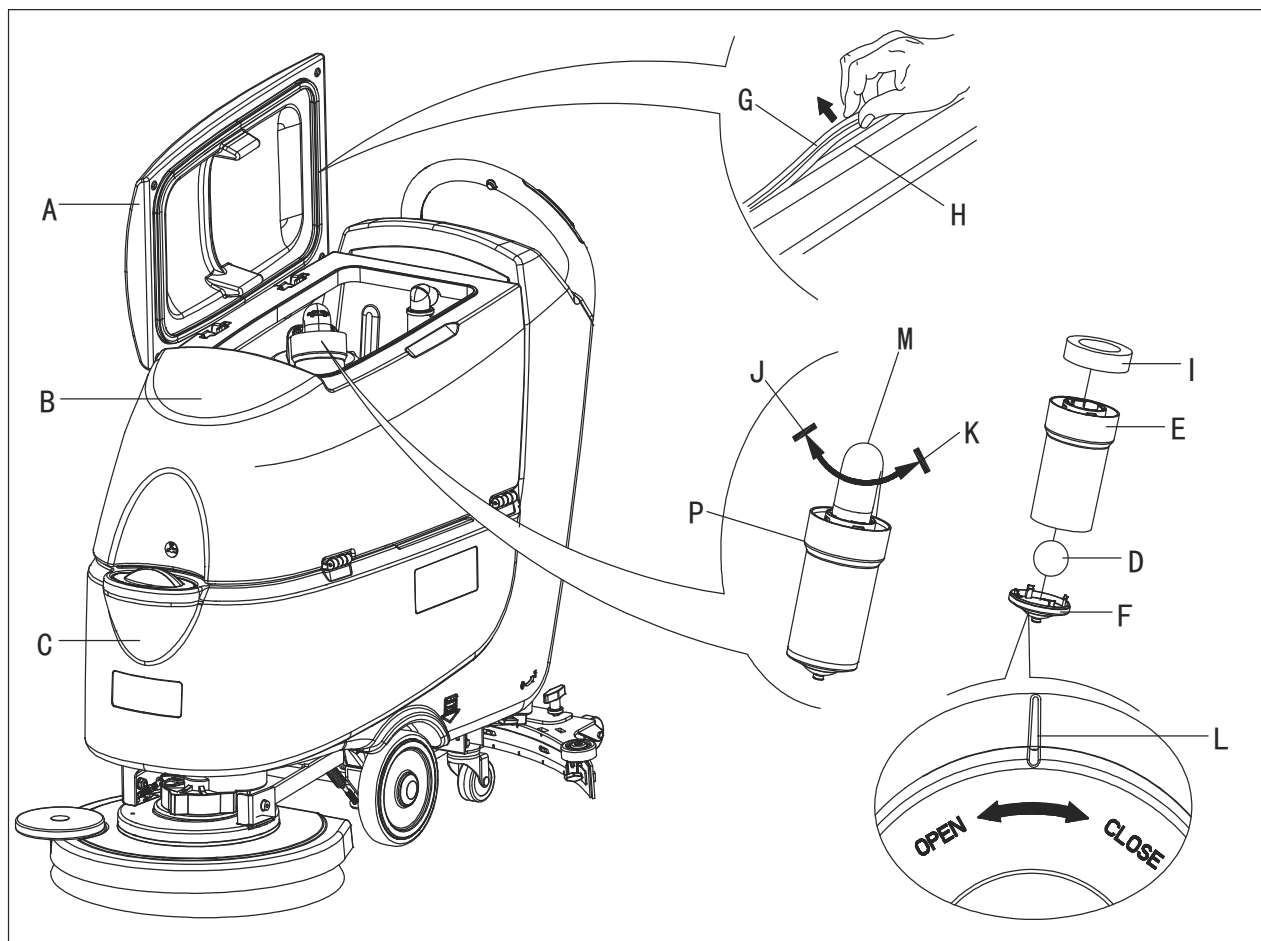
**Figure 23**

DETERGENT TANK CLEANING

(For machines with Chemical Mixing System)

Clean the detergent tank (G, Figure. 24) as shown below:

1. Drive the machine on a level floor.
2. Turn the ignition key (A) to "0".
3. Open the cover (B) and check that the recovery water tank (C) is empty; if necessary empty it with the drain hose (D). Close the cover (B).
4. Carefully lift the tank (C).
5. Unscrew the plug (E) and disconnect the hose (F) from the tank (G).
6. Remove the tank.
7. Wash the tank in the appointed disposal area.
8. Install the tank (G) and connect the hose (F).
9. After draining the detergent tank, drain the Chemical Mixing System too by running the system with clean water only.

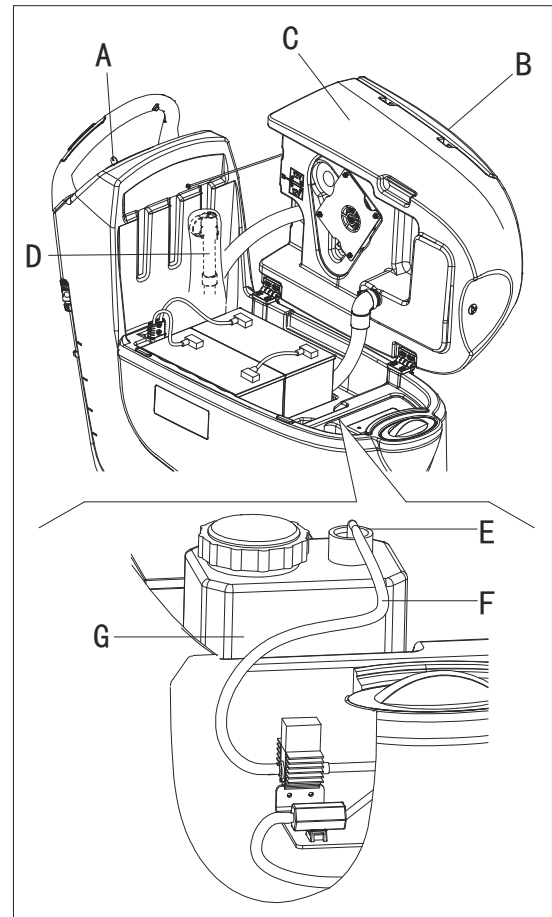

Figure 24

MACHINE WORKING HOUR CHECK

1. Turn the ignition key (A, Figure. 25) to "I".
2. Press the switch (B), the hour meter (C) begins to work and it at the same time shows the total number of working hours (scrubbing/drying) performed by the machine.
3. Release the switch (B).
4. Turn the ignition key (A) to "0".

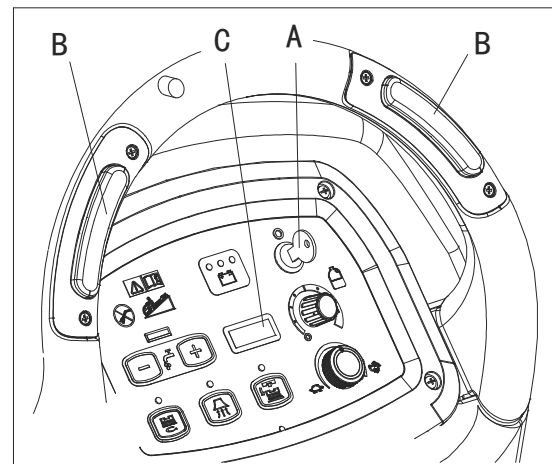

Figure 25

FUSE CHECK/REPLACEMENT

1. Turn the ignition key (A, Figure. 26) to "0".
2. Disconnect the power supply cable (C, Figure. 26) from the electrical mains.
3. Remove the screws (C .Figure27) on control panel (D), then turn over the PCB to find the fuse (A, B, Figure 27).
4. Check/replace the following fuses:
 - A) F1 fuse, low power circuit fuse:(5A)
 - B) F3 fuse, Brush release fuse: (20A)
5. Perform steps 1 to 3 in the reverse order.
6. Check/press down or replace the following breakers:
 - E) F5breaker, vacuum motor circuit breaker: (30A)
 - F) F4 breaker, traction system circuit breaker: (12A) (*)
 - G) F2breaker, brush motor circuit breaker: (30A)

(*): Only for machine with traction

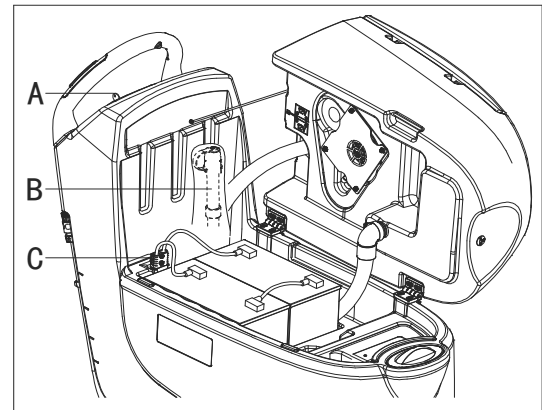

Figure 26

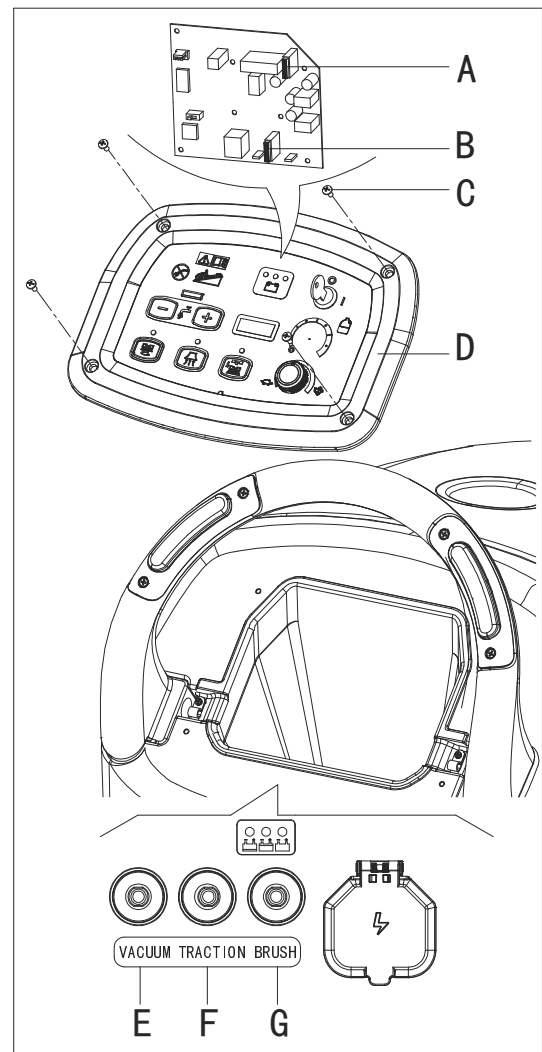

Figure 27

ACCESSORIES/OPTIONS

In addition to the standard components, the machine can be equipped with the following accessories/options, according to the machine specific use:

For further information concerning the above-mentioned optional accessories, contact an authorized Retailer.

ACCESSORIES/OPTIONS

See “Parts List” section

1. WET or GEL/AGM batteries
2. Mop and trash kit
3. Pads of different materials
4. Chemical Mixing System
5. Debris collection box

TROUBLESHOOTING

Trouble	Probable causes	Remedy
The motors do not work; no warning light turns on.	The battery connector is disconnected.	Connect the battery connector.
	The batteries are completely discharged.	Charge the batteries.
The machine does not move (Only for machine with traction)	The machine has been turned on by using the ignition key and by keeping one of the switches pressed.	Turn the ignition key to “0”, then try to start the machine again without pressing the switches.
The 3 battery charge indicators are flashing simultaneously.	Brush motor overload.	Use less aggressive brushes
	Foreign materials (tangled threads, etc.) which may prevent the brush from rotating.	Clean the brush hub.
The brushes do not work, the red warning light is on.	The batteries are discharged.	Charge the batteries.
The recovery water vacuuming is insufficient.	The recovery water tank is full.	Empty the tank.
	The hose is disconnected from the squeegee.	Connect.
	The vacuum grid is clogged or the float is stuck closed.	Clean the grid or check the float.
	The squeegee is dirty or the squeegee blades are worn or damaged.	Clean and check the squeegee.
	The tank cover is not properly closed, or the gasket is damaged, or the Bend tube is clogged.	Close the cover correctly, or replace the gasket or clean the Bend tube.
The recovery water tank is dirty.	Clean.	
The solution flow to the brushes is insufficient.	The solution/clean water filter is dirty.	Clean the filter.
The squeegee leaves marks on the floor.	There are debris under the squeegee blades.	Remove the debris.
	The squeegee blades are worn, chipped or torn.	Replace the blades.
	The squeegee has not been adjusted with the knob.	Adjust.



NOTE

Machine with battery charger installed, cannot operate if the charger is not on board. In case of battery charger malfunction, contact an authorized Service Center.

For further information refer to the Service Manual, available at any Service Center.

SCRAPPING

Scrap the machine by the qualified waste treatment institution.

Before the machine is scrapped, please take away and segregate below subassembly that relevant laws and regulations request must be disposed in appropriate way.

- Battery
- Brush/Pad-holder
- Plastic hose and plastic parts
- Electrical and electronic components (*)

(*) Please contact our company service center for any destroy of electrical and electronic components.



Nilfisk A/S

Kornmarksvej 1 DK-2605 Brøndby Denmark

Tel:+45 43 23 81 00 Fax:+45 43 43 77 00

www.nilfisk.com

